

ASSEMBLY INSTRUCTIONS:

- SEE APPLICABLE S570 SERIES SECTION I. FOR INSTRUCTIONS.
- REFERENCE APPLICABLES570 SERIES FOR ADDITIONAL STANDARDS AND INSTRUCTIONS THAT MAY APPLY.
- ALL FASTENERS, FITTINGS AND PLUGS TO BE TORQUED PER S574 UNLESS OTHERWISE SPECIFIED.
- NOTE A: TORQUE MOUNTING BOLTS TO 57-68 N-m "AS RECEIVED" OR 47-56 N-m "LUBRICATED"

BILL OF MATERIAL

ITEM NO.	QTY.	PART NO.	DESCRIPTION
1	2	1020542A	VALVE
2	1	P4885A	PLATE
3	4	M422B	SCREW, DRIVE
4	1	1020412B	VALVE ASSY, CONTROL
5	1	MA1052U	SCREW, SOCKET HEAD
6	3	MA1052B	SCREW, SOCKET HEAD
7	1	PM1349AA	WASHER
8	1	M2006C	SCREW, HEX HEAD

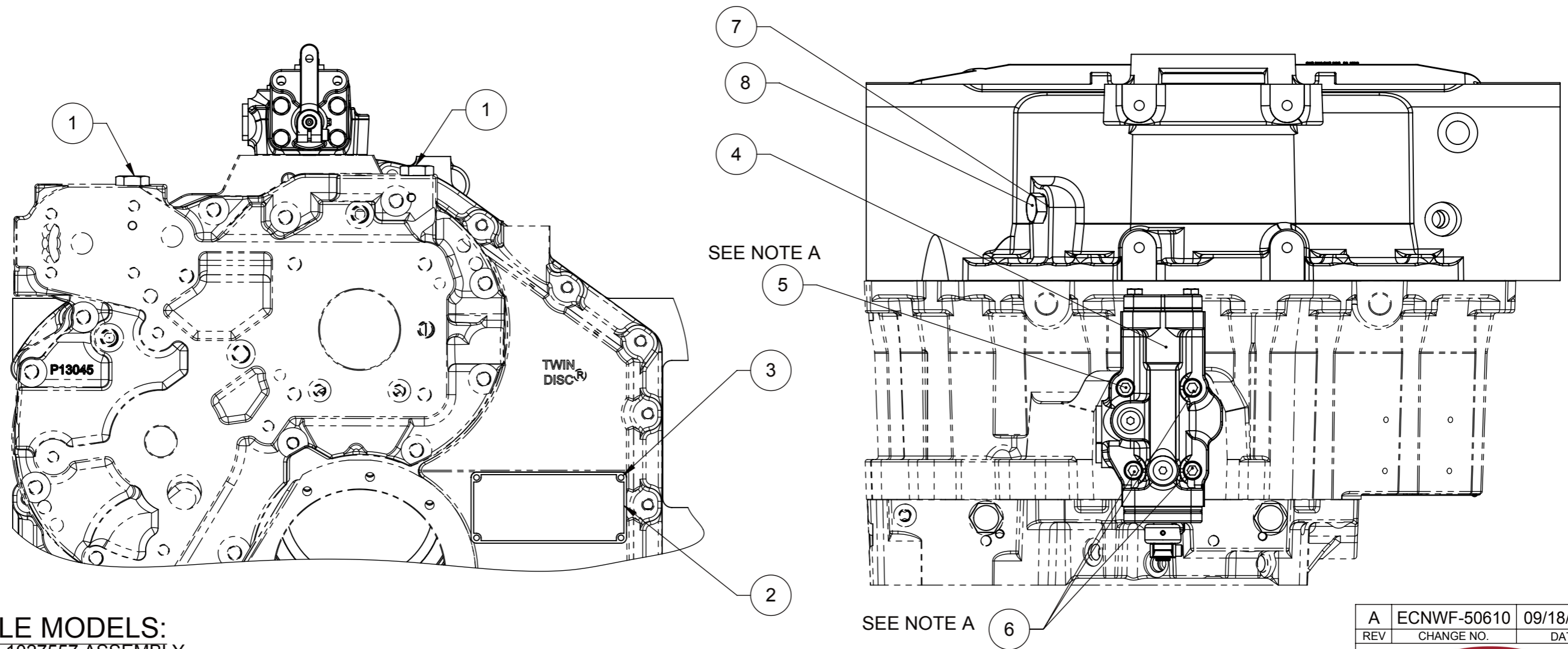

APPLICABLE MODELS:

MG-5136A PER 1027557 ASSEMBLY
ASSEMBLY INSTRUCTIONS: S570DX

MG-5136RV PER 1027561 ASSEMBLY
ASSEMBLY INSTRUCTIONS: S570DX

MG-5136SC PER 1027560 ASSEMBLY
ASSEMBLY INSTRUCTIONS: S570DW

FIRST USE ASSEMBLY: 1027557	WEIGHT: 8.27 kg
FIRST USE MODEL: MG-5136A	WR ² : kg-m ²
SIMILAR TO:	
METRIC	
NOTICE! THIS PRINT CONTAINS PROPRIETARY INFORMATION AND IS NOT TO BE USED IN ANY MANNER DETRIMENTAL TO THE INTEREST OF TWIN DISC, INCORPORATED	
THIS NOTICE IS NOT INTENDED TO NULLIFY OR LIMIT RIGHTS GRANTED TO THE U.S. GOVERNMENT OR OTHERS BY CONTRACT.	

 THIRD ANGLE PROJECTION	UNLESS OTHERWISE SPECIFIED MACHINED DIMENSIONS X ±0.75 X.X ±0.25 X.XX ±0.13 ALL ANGULAR TOLERANCES ±1° GEOMETRIC TOLERANCING PER ASME Y14.5M 1994
-------------------------------	--

MATERIAL:	DATE: 09/27/2012
HEAT TREAT:	SCALE: 1:4
DESCRIPTION: GROUP, CONTROL MECHANICAL VALVE LESS TROLL	DRAWN BY: LT
	CHECKED BY: JMF
	APPROVED BY: ALC

A	ECNWF-50610	09/18/2015
REV	CHANGE NO.	DATE
 RACINE, WI 53403 - USA		
1027558		
DWG SIZE: A3	SHEET: 1 OF 1	REV: A