

**GENERAL NOTES:**

- a.) REFER TO PRODUCT LIST WHEN ORDERING PARTS
- b.) REFER TO CARE & OPERATION MANUAL FOR ADDITIONAL INFO.
- c.) REFER TO PIPING DRAWING 1029340A FOR HYDRAULIC CONNECTIONS OR 1029340C FOR PNEUMATIC CONNECTIONS

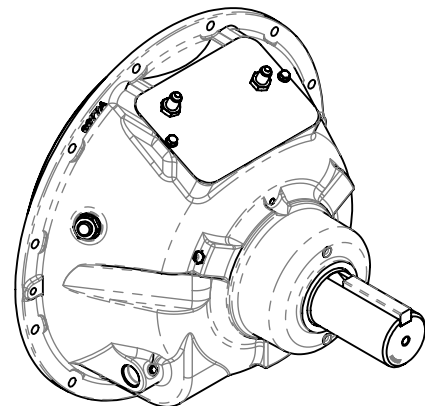

FIRST USE ASSEMBLY: 1028700G		WEIGHT:	lb	 THIRD ANGLE PROJECTION	MATERIAL:	DATE:	- ECNWF-24744 12/17/2014	
FIRST USE MODEL: RO211P3		WR <sup>2</sup> :	lb-in <sup>2</sup>		HEAT TREAT:	12/10/2014	REV	CHANGE NO.
SIMILAR TO:				UNLESS OTHERWISE SPECIFIED MACHINED DIMENSIONS X.X ±0.030 X.XX ±0.010 X.XXX ±0.005 ALL ANGULAR TOLERANCES ±1° GEOMETRIC TOLERANCING PER ASME Y14.5M 1994	DESCRIPTION:	SCALE:	 RACINE, WI 53403 - USA	
<b>INCH</b> <small>NOTICE! THIS PRINT CONTAINS PROPRIETARY INFORMATION AND IS NOT TO BE USED IN ANY MANNER DETRIMENTAL TO THE INTEREST OF TWIN DISC, INCORPORATED. THIS NOTICE IS NOT INTENDED TO NULLIFY OR LIMIT RIGHTS GRANTED TO THE U.S. GOVERNMENT OR OTHERS BY CONTRACT.</small>					PTO, RO211HP3 INSTALLATION DRAWING	1:4	1028710E	
				APPROVED BY: DAJ	DRAWN BY: YU CHECKED BY: JEL	DWG SIZE: B	SHEET: 1 OF 1	REV: -