

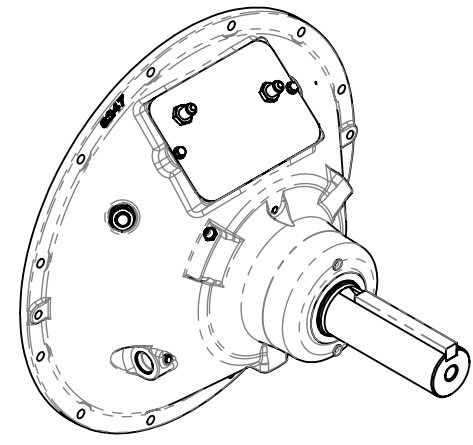

GENERAL NOTES:
 a.) REFER TO PRODUCT LIST WHEN ORDERING PARTS.
 b.) REFER TO CARE & OPERATION MANUAL FOR ADDITIONAL INFO.
 c.) REFER TO PIPING DIAGRAM 1029340A FOR HYDRAULIC CONNECTIONS OR 1029340C FOR PNEUMATIC CONNECTIONS



FIRST USE ASSEMBLY: 1028705D		WEIGHT: lb	THIRD ANGLE PROJECTION	MATERIAL:	DATE: 12/10/2014	- ECNWF-24744 12/17/2014	
FIRST USE MODEL: RO111HP2						WR ² : lb-in	REV CHANGE NO. DATE
SIMILAR TO:		INCH		HEAT TREAT:			 RACINE, WI 53403 - USA
<small>NOTICE! THIS PRINT CONTAINS PROPRIETARY INFORMATION AND IS NOT TO BE USED IN ANY MANNER DETRIMENTAL TO THE INTEREST OF TWIN DISC, INCORPORATED. THIS NOTICE IS NOT INTENDED TO NULLIFY OR LIMIT RIGHTS GRANTED TO THE U.S. GOVERNMENT OR OTHERS BY CONTRACT.</small>		<small>UNLESS OTHERWISE SPECIFIED MACHINED DIMENSIONS X.X ±0.030 X.XX ±0.010 X.XXX ±0.005 ALL ANGULAR TOLERANCES ±1° GEOMETRIC TOLERANCING PER ASME Y14.5M 1994</small>		DESCRIPTION: PTO, RO111HP2 INSTALLATION DRAWING		SCALE: 1:4	
						DRAWN BY: YU	
<small>THIS NOTICE IS NOT INTENDED TO NULLIFY OR LIMIT RIGHTS GRANTED TO THE U.S. GOVERNMENT OR OTHERS BY CONTRACT.</small>				APPROVED BY: DAJ		CHECKED BY: JEL	
						DWG SIZE: B SHEET: 1 OF 1 REV: -	
						1028715D	