

VETH BOW THRUSTERS



VETH
PROPULSION

BY TWIN(DISC)

THE POWER 360°
TO TURN YOUR WORLD



Twin Disc has been designing, engineering and manufacturing products to make power more productive in marine and land-based equipment since 1918. Our marine products range from transmissions, multiple drives and propellers to boat management and (engine) control systems.

Twin Disc develops power transmission products that meet real world needs, exceed operating requirements, improve productivity and offer a service life that enhances equipment value. Our products and systems are precision manufactured, time proven and field tested to provide you with optimal performance, reliability and cost effectiveness.

Though our product portfolio and expert engineering team, Twin Disc provides you with a tailor-made solution, anything from power transmission components to sophisticated con-

trols to manage power output. Working together, we'll help you select the right piece of equipment you're going to use. New, repowering or refitting, we provide the best solution to optimize the performance and reliability of your machine.

Twin Disc offers more than a century of diverse and successful application experience, responsive engineering collaboration, and world-wide product support. And now, Twin Disc has added Veth Propulsion to its family of products offering a strong history of reliable solutions.

About Veth Propulsion

Veth Propulsion, by Twin Disc, is a customer-oriented Dutch thruster manufacturer. A family-owned company, established in Papendrecht in the Netherlands in 1951, and international player which is leading in quality, service, innovation and sustainability.

Shallow draft

A major advantage of a horizontal propeller is that optimum thrust is achieved at minimum draft, without vulnerable parts sticking out beneath the vessel. The shallow draft thrusters provide high thrust even at cruising speed, because the propeller draws up the water over a short length.

ted in all of its products. So there are only few moving parts outside the gearbox, and all Veth thrusters are built with minimal ductwork due to its compact construction. The use of durable and high quality materials makes for a robust and reliable construction, for long life requiring little maintenance.

Driven by simplicity

Veth Propulsion believes in the power of simplicity, combined with robustness and sustainability, which you will find reflec-

Relying on our expertise and decades of experience, we can give you advice on the most suitable solution and possibilities. Please contact us for more information or visit our website.



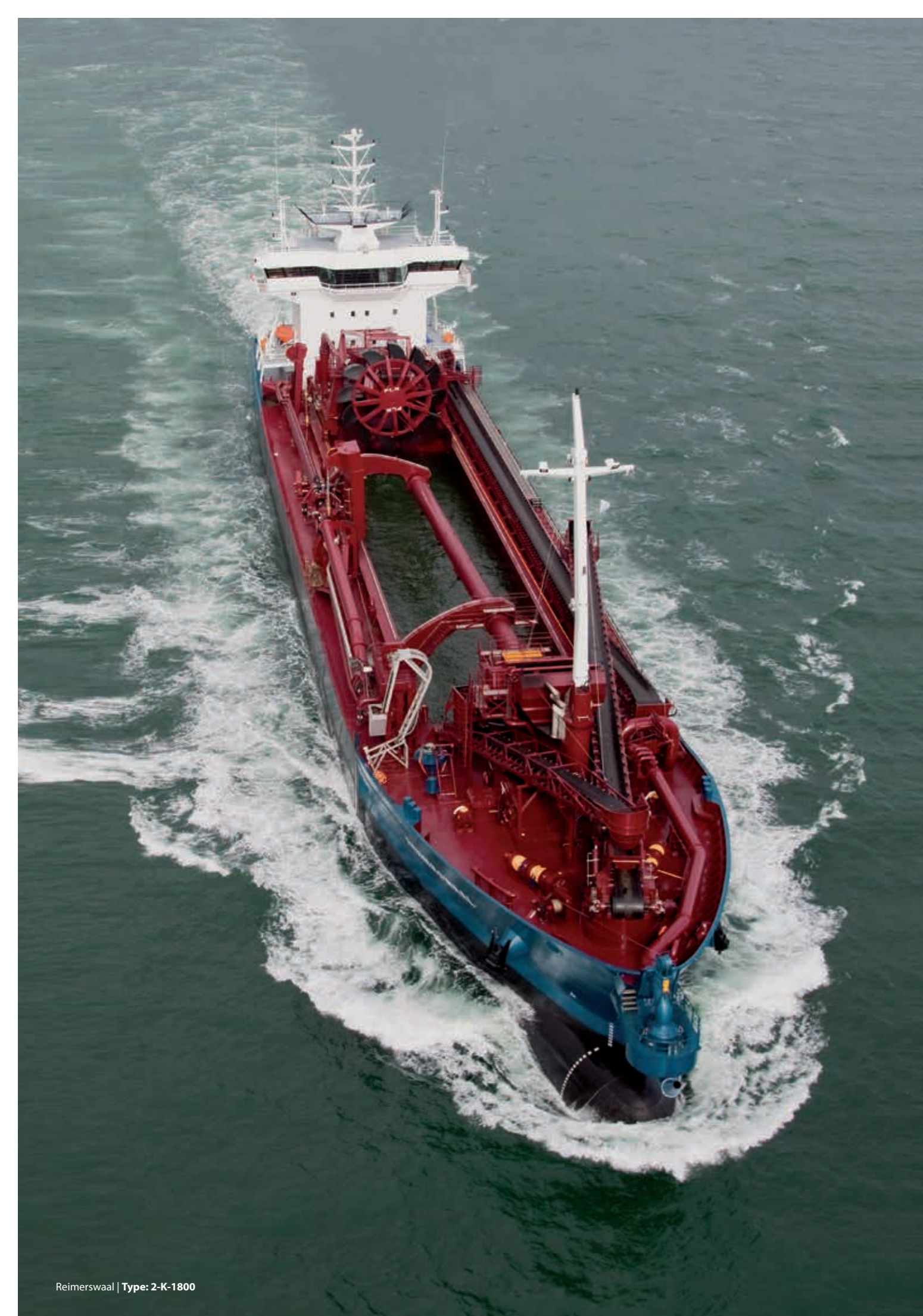

Veth Jet

The Veth Jet channel bow thruster is an invention of Jan Veth, which was launched in 1970 in response to the demand from the market for a thruster that could function optimally 360° with a shallow draft.

The Veth Jet is still used extensively in the inland and maritime navigation, but the thruster is also ideal for multiple sectors such as dredging, crane vessel etc.

Our thrusters are fully equipped for harsh applications such as dredging and offshore in order to allow heavy duty use. Such as operation specifically suited for highly contaminated water surrounding the thruster or the application of robust coolers for continuous use.



Why a Veth Jet?

- Optimum thrust at minimum draft (once the propeller is under water)
- 360° of steering (in case of a 4-channel Veth Jet)
- High thrust; approx. 11 kg per kW
- Easy to install and requires minimal maintenance
- Possibility to change propeller without (dry) docking
- The propeller only needs to rotate in one direction; it is optimized for this direction of rotation
- No protruding parts under the surface

Operation

The basic principle for this rugged construction is simple, effective and largely self-sufficient. Moreover, the entire thruster including gearbox is manufactured in-house. The concept is reliable, well thought out and is continuously improved upon to always guarantee the best quality. How does it work?

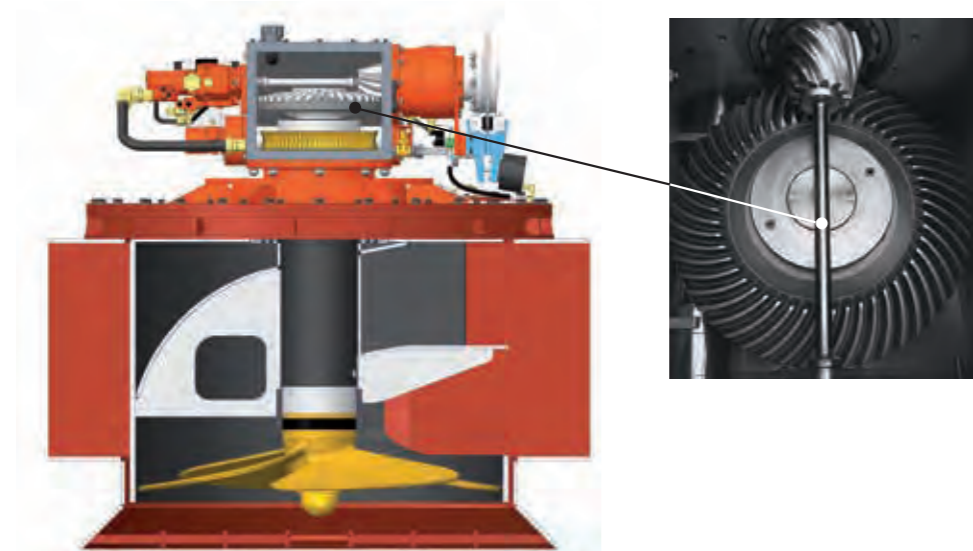

Veth Propulsion uses spiral-cut bevel gears. This type of gear ensures smooth gearing with a lower noise level. The shaft that drives the hydraulic pump is directly connected to the pinion gear; it is one example of the well thought-out design of a Veth Jet. A simple, robust and durable solution for driving the pump.

Type 2-k /3-k /4-k	Max. power kW (Hp)	Nominal revolutions rates/min	Reduction	Propellerdiameter in mm
K-800	191 (260)	1800	3,071:1	780
K-1000	283(385)	1800	3,071:1	980
K-1000NR	280 (381)	2100	3,417:1	980
K-1200	404 (550)	1800	4:1	1180
K-1300	478 (650)	1800	4:1	1280
K-1300A	577 (785)	2100	4,727:1	1280
K-1400	618 (842)	1800	4,909:1	1420
K-1650	956 (1302)	1800	5,091:1	1650
K-1700	1037 (1412)	1800	5,091:1	1700
K-1750	1102 (1501)	1800	5,091:1	1750
K-1800	1257 (1703)	1800	5,583:1	1800

- Thrust is approx 11 kg per kW
- Types K-800 to K-1300 are available as a vertical motor execution
- The indicated values are based on intermediate duty and are subject to application and classification
- Values are for indication only. Power ranges for your specific application are available on request
- No rights can be taken from this sheet and data is subject to change without notice

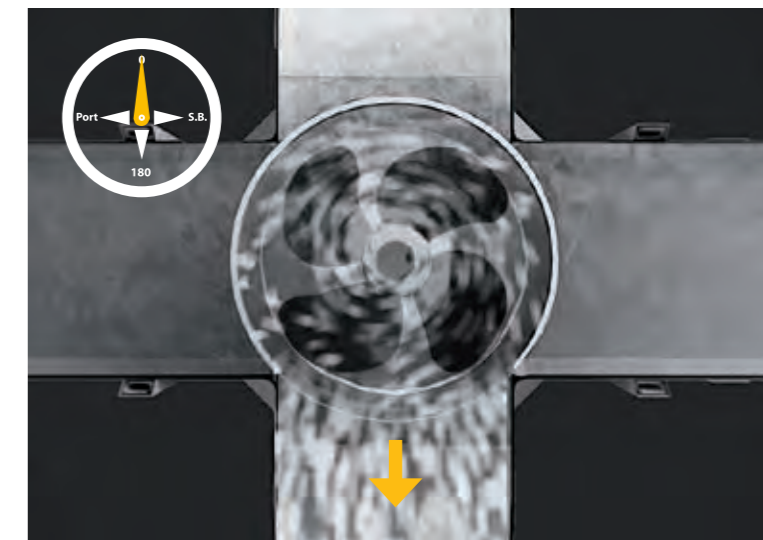
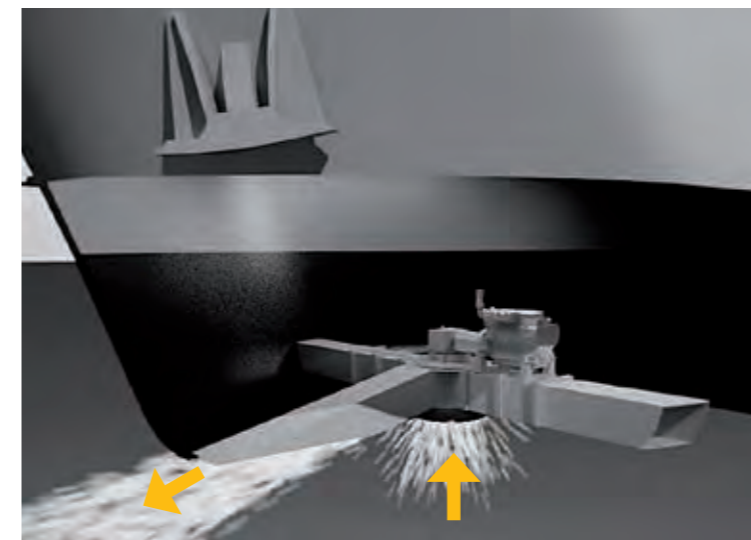

Horizontal propeller

The Veth Jet works on the principle of a horizontal impeller, drawing water from below the vessel, thus eliminating the risk of air being drawn in when operating at shallow draft. Water is then deflected by 90° into lateral channels by a deflector screen which is capable of rotation to vary the direction of thrust.

Impelling and maneuvering

By means of a 360° rotating deflector screen (which can turn to both sides), the water is deflected 90° and forced through a channel. The steering time from port to starboard is approximately seven seconds. Options of 2, 3 or 4 channel designs are available with the option to use 3 and 4 channel units for either emergency propulsion or as an aid to slowing the vessel.

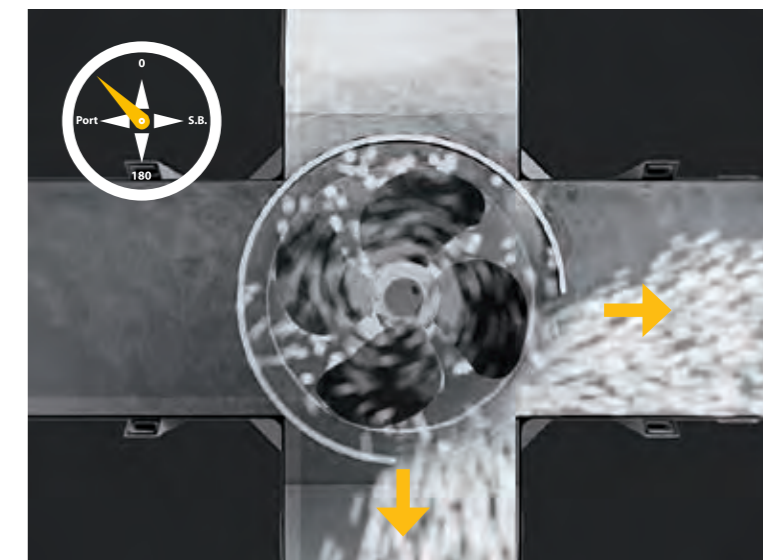

For our 2-channel version we have developed a system in which the steering angle of the drum and the speed of the diesel engine is continuously variable in a setup using one infinitely adjustable handle (which moves from side to side, like a tunnel). The operation is thus highly effective and very responsive!

On the 3- and 4-channel versions, r.p.m. adjustment and steering angle are thus combined in one lever.



Versions of the Veth Jet

The Veth Jet can be driven by a diesel engine, electric motor or hydraulically. An electric or diesel-powered version? The motor can be placed on one of the side channels and we can also supply a ready-made engine foundation.

The Veth Jet is suitable for various disciplines and available in several variants. No space for a horizontal drive motor? No problem. Then you can choose a vertical-drive unit.

Also, a Veth Jet with gondola belongs to the possibilities. Choose this option if the hull design of your vessel is not suitable for a regular installation. The Veth Jet is supplied complete with motor mounted in a custom-made gondola, including the accessories such as a cooler, hydraulic tank and control cabinet completely installed and connected.

Custom solutions

The Veth Jet is available in many configurations and is suitable for multiple applications across multiple market segments. Your wish is our starting point, so... if you want to know which version of the Veth Jet is right for you, please contact us!

Impossible to sail through narrow locks without a 4 channel Veth Jet bow thruster!

Ad Toonen, Technical Superintendent,
short sea specialist Wijnne Barends



Diesel driven



Electric driven



Vertical electric version



With gondola



William Shakespeare | Type: 4-K-1200



Fox Sunrise | Type: 3-K-1200



Naomi E | Type: 3-K-800



US Navy | Type: 3-K-1200



Vorstenbosch | Type: 2-K-1400

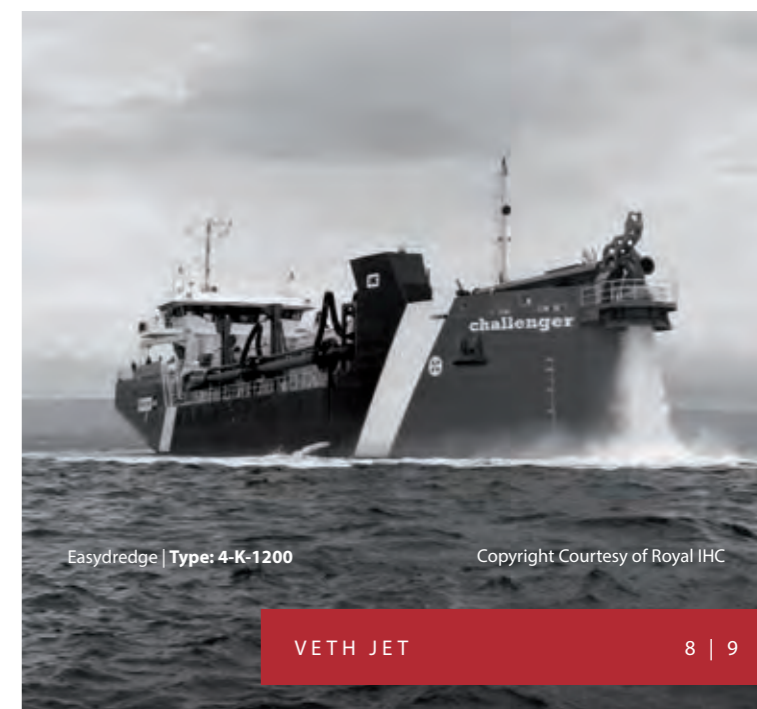

Easydredge | Type: 4-K-1200

Copyright Courtesy of Royal IHC



Coastal Challenger | Type: CJ-1000+VZ-400

Veth Compact Jet

Are you looking for a bow thruster which ensures minimal noise at maximum thrust and minimum draft, which also can be used as propulsion? Then the Veth Compact Jet offers you a suitable and unique solution.

The Veth Compact Jet can be found only at Veth Propulsion. It is part of the shallow draft family: with its horizontal propeller. A special feature of the Veth Compact Jet is that the propeller is placed at an angle of 17°. In practice this means more efficiency and higher thrust on a sailing vessel.

Because you can install the Veth Compact Jet in rubber mounts and the thrust water does not flow through the vessel's structure (but through an integrated channel), the Veth Compact Jet is very quiet in operation.



Why a Veth Compact Jet?

- Higher efficiency, especially at higher speeds, due to the propeller angle of 17°
- Minimum noise / vibrations at maximum thrust (flexible suspension) and minimum draft
- Optimum maneuverability: maximum thrust possible through 360°
- Compact and easy to install
- No channels are required
- Suitable for DP
- Also suitable as a propulsion

For Scylla, the Veth Compact Jet is the ideal combination of a silent bow thruster and emergency propulsion. In conjunction with the Veth Z-drives our ships are very maneuverable, even in high winds.

Bart Vos, Naval Architect, Scylla AG

Bureau veritas CLEANSHIP

Veth Propulsion is continually looking for solutions to meet the highest quality standards and latest regulations, including those for the environment. For example, by limiting the impact of our operations on the environment. The Bureau Veritas CLEAN VESSEL notation is an additional notation that imposes requirements on waste management, anti-fouling systems and sealing systems.

That is why we have redeveloped a new sealing system for all thrusters. These seals separate large quantities of lubricant from the environment - thus meeting environmental requirements while maintaining the performance of our high capacity thrusters.

Operation

The water is drawn in by the propeller at an angle from beneath the vessel and is deflected away at a smoother angle, which greatly increases efficiency. Due to the hydro-dynamically streamlined housing, integrated into a rotating structure, the water is thrust in any desired direction with great force so that the outgoing water will always be blown away from the propeller, regardless of the thrust direction.

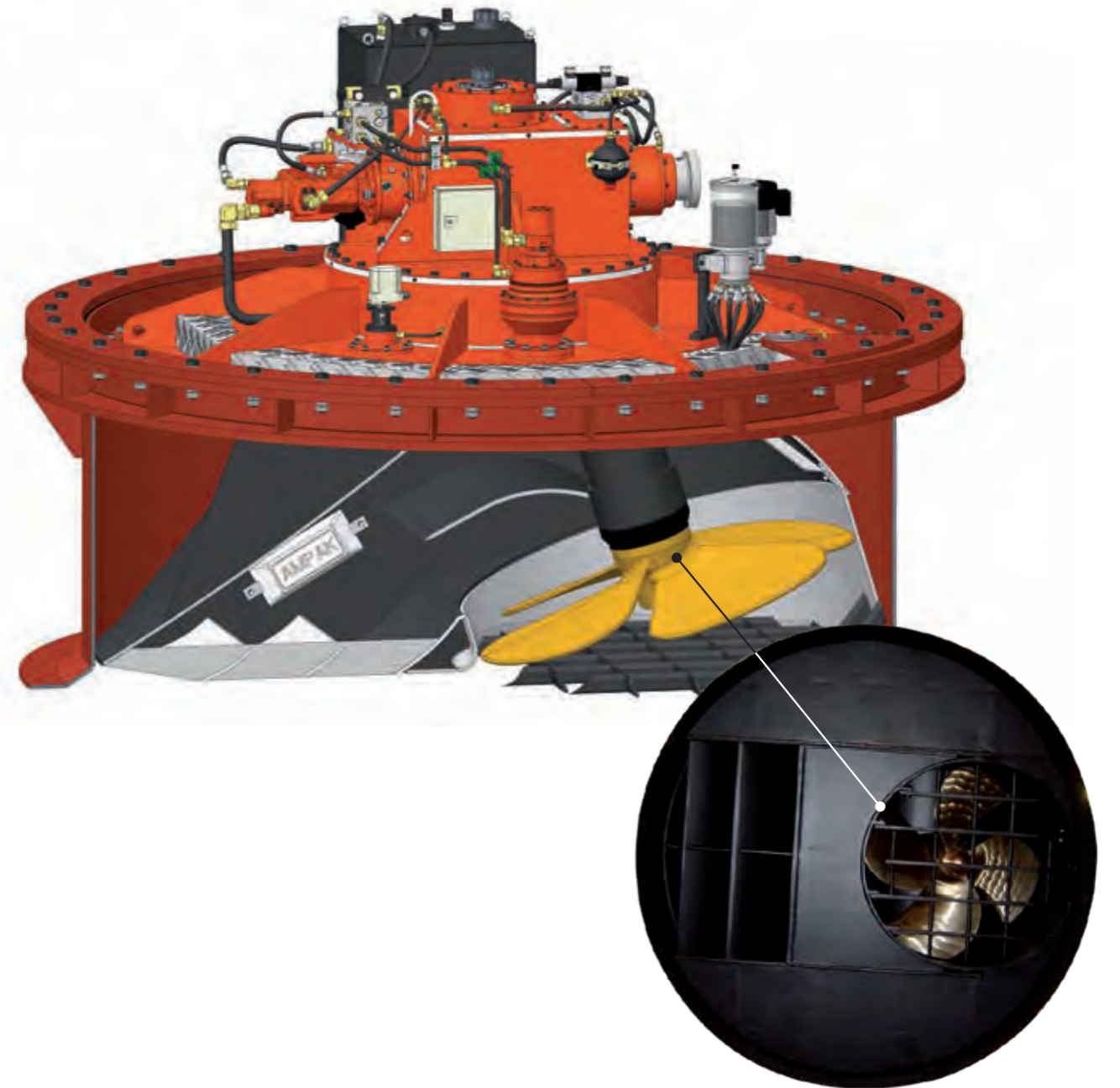
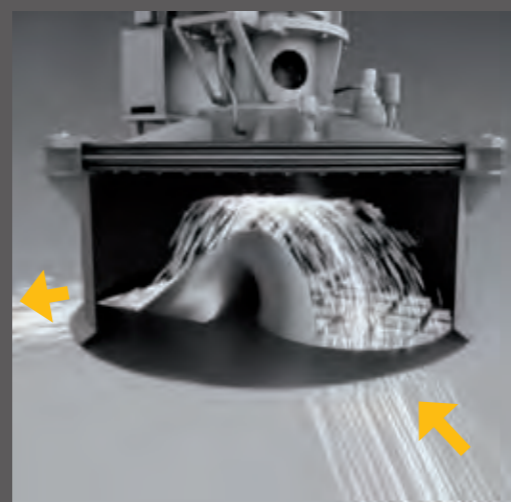
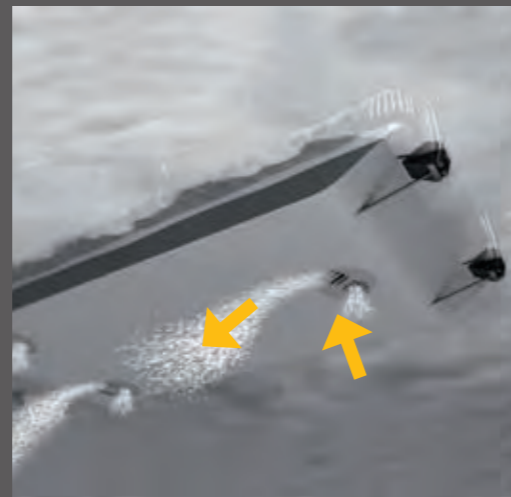

Type	Max. electrical power kW (Hp)	Nominal revolutions rates/min	Reduction	Propeller-diameter in mm
CJ-800	200/(272)	1800	3,540:1	1040
CJ-1000	340/(463)	1800	3,540:1	1040
CJ-1000V	340/(463)	1500	2,632:1	1040
CJ-1200	483(658)	1800	3,933:1	1240
CJ-1200V	483(658)	1000	2,118:1	1240
CJ-1400	615/(836)	1800	4,55:1	1400
CJ-1400V	616/(836)	1000	2,45:1	1400

- Thrust is approx. 9,5 kg per kW
- The indicated values are based on intermediate duty and are subject to application and classification
- Values are for indication only. Power ranges for your specific application are available on request
- No rights can be taken from this sheet and data is subject to change without notice



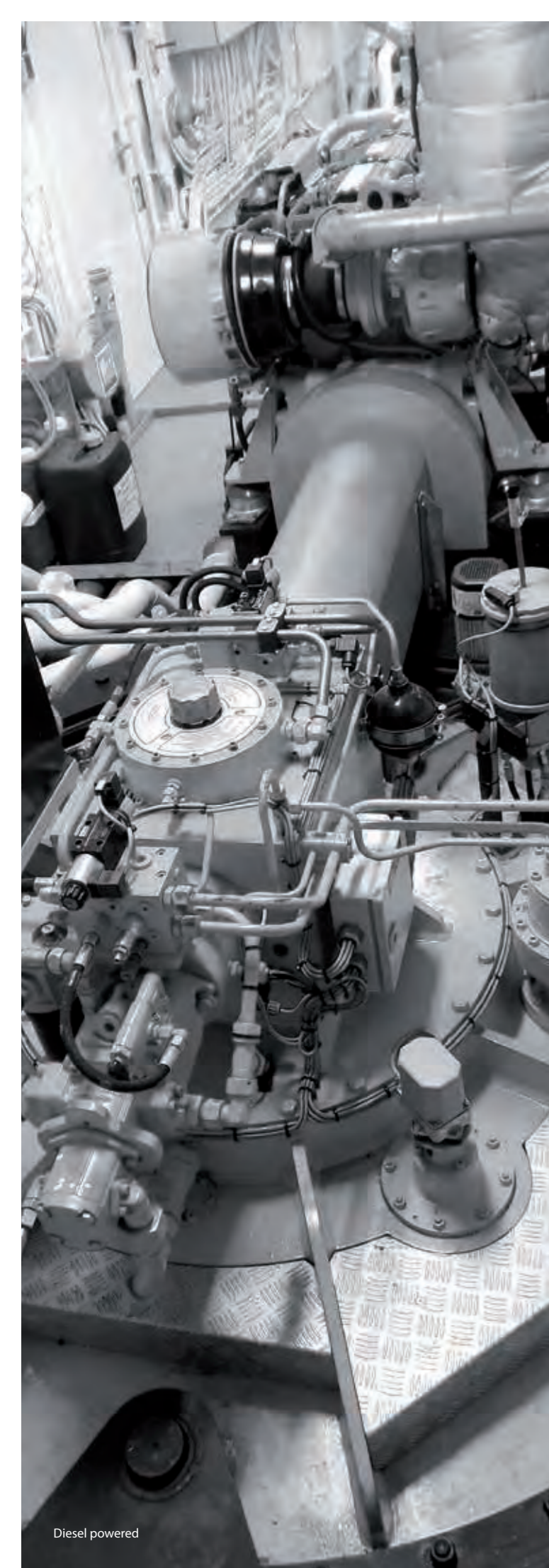

Ideal to use as propulsion

By combining maximum thrust in any position with the fact that there are no vulnerable parts protruding below the hull, the Veth Compact Jet is also ideal to use as propulsion. Because the propeller shaft is mounted at a 17° angle in the thruster, the intake duct is directed forward allowing it to draw in water more easily, even at higher speeds. The outflow channel rotates simultaneously, with the same thrust in any direction, resulting in stable and predictable steering performance. The hydraulic system is also similar to that of our Z-drives.

This solution has already been applied to, for example, Multicats and in making barges self-propelled.

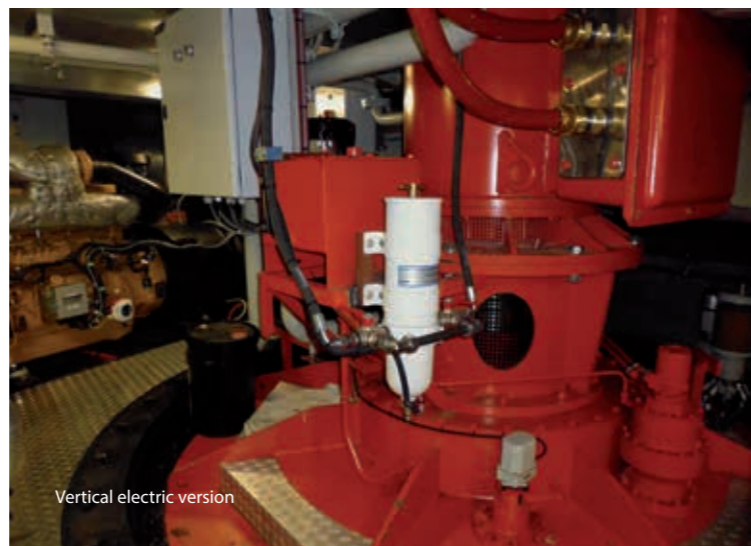



Union XIV | Type: VSG-1200

Veth Steering Grid

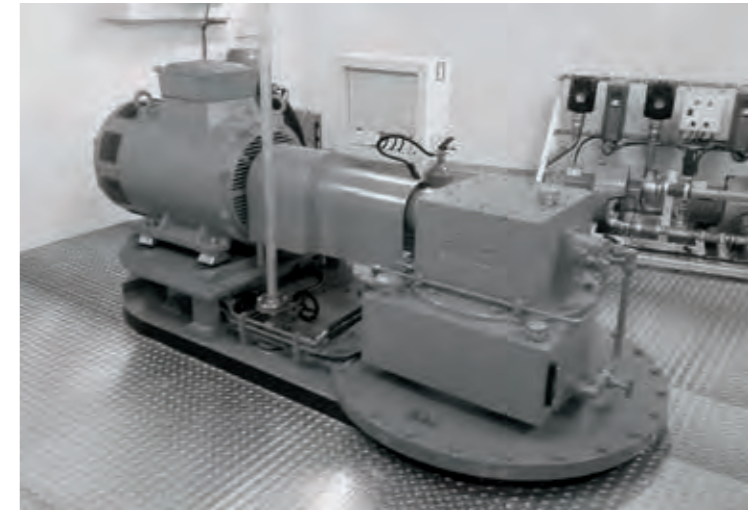

Are you looking for a 360° steerable thruster, which takes up little space and is easy to build? Then the Veth Steering Grid may offer the solution.

Thrust

With a Veth Steering Grid you achieve optimal thrust at minimum draft by the use of the horizontally mounted propeller. Even at speed and with no parts protruding under the vessel. The Veth Steering Grid makes use of existing technology found in the successful Veth Jet, like the worm wheel and gear transmission.

Why a Veth Steering Grid?

- No channels are required
- Maximum thrust at minimum draft
- 360° steering
- Compact and easy to install
- Low maintenance due to robust construction

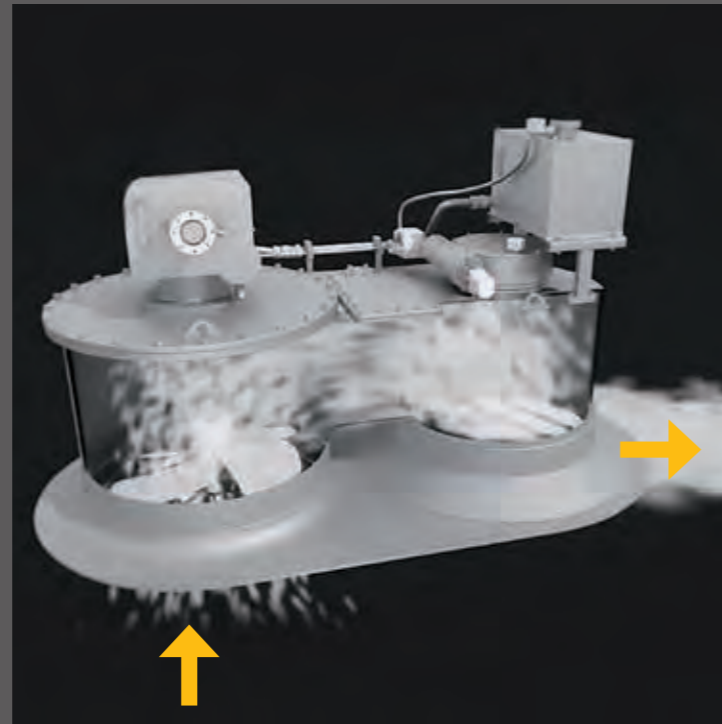

Operation

With the aid of a horizontal propeller, the water is drawn in from under the vessel. Then the water is guided via a hydro-dynamically streamlined house to the outside through a grid. This grid is steerable through 360°.

The Veth Steering Grid is available in diesel, electric or hydraulic drive. In all cases the drive motor can be supplied with the bow thruster in a complete package.

Are you looking for a similar solution for smaller capacities? Then the Veth Compact Grid might be an option for you.

A thruster manufacturer with enthusiastic and committed people. They understand the business, pay attention to detail and have provided us with great products for years.

Fam. Wanders, Owners Unibarge



Veth Steering Grid has different options available:

- Diesel
- Electric
- Hydraulic

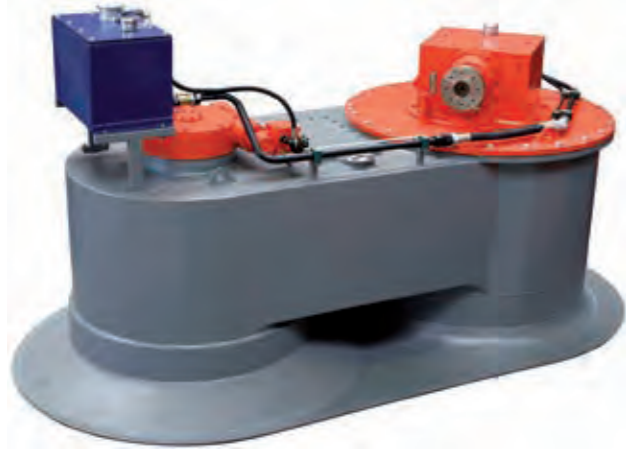

Diesel driven



Electric driven

Type	Max. electrical power kW (Hp)	Nominal revolutions rates/min	Reduction	Propeller diameter in mm
VSG-800	191 (260)	1800	3,07:1	780
VSG-1000	265 (360)	1800	3,07:1	980
VSG-1200	404 (550)	1800	4:1	1180
VSG-1300	478 (650)	1800	4:1	1280
VSG-1300A	577 (785)	2100	4,727:1	1280
VSG-1400	550 (842)	1800	4,455:1	1420

- Thrust is approx. 7,5 kg per kW
- Types VSG-800 to VSG-1300 are available as a vertical motor execution
- The indicated values are based on intermediate duty and are subject to application and classification
- Values are for indication only. Power ranges for your specific application are available on request
- No rights can be taken from this sheet and data is subject to change without notice



Quattro | Type: VSG-1200



Statendam | Type: VSG-1200



Hydro Flow | Type: VSG-1000L Courtesy of Neptune Marine

Veth Compact Grid

If you are looking for a compact thruster that is easy to install, provides maximum thrust at minimum draft and is also to be used as emergency propulsion? Then the Veth Compact Grid offers a suitable solution.

The Veth Compact Grid offers the advantages of two existing Veth solutions: the simplicity of the Veth Steering Grid and the angled propeller Veth Compact Jet.

Why a Veth Compact Grid?

- Very simple and robust concept
- Higher efficiency by placing propeller at an angle of 17°
- Maximum thrust at minimum draft
- 360° steering
- Price-wise very affordable
- Can be used as emergency propulsion
- Compact and easy to install

Electrical and hydraulic drives possible



Mobi | Type: VCG-600



Kostra 2 | Type: VCG-600

Type VCG-600, electric powered

Operation

The propeller is driven by a hydraulic or electric motor, which is placed directly onto the propeller. The VCG-750 makes use of a reduction gear. The water is drawn in by the propeller at an angle from beneath the vessel. This requires less deflection of the flow of water, resulting in higher efficiency. Then the water is guided via a hydro-dynamically streamlined house to the outside through a grid. This grid is steerable through 360°.

Simplicity is key

The innovative aspect of the Veth Compact Grid is that simplicity has been even more central in its development. The lack of a gearbox provides low maintenance at an attractive price.

Type	Max. electrical power kW (Hp)	Nominal revolutions rates/min	Propeller diameter in mm
VCG-400	50 (68)	1500	400
VCG-600	99 (135)	1000	580
VCG-750	177 (241)	750	750

- Thrust is approx. 9,5 kg per kW
- The indicated values are based on intermediate duty and are subject to application and classification
- Values are for indication only. Power ranges for your specific application are available on request
- No rights can be taken from this sheet and data is subject to change without notice

No gearbox, direct drive with electric motor

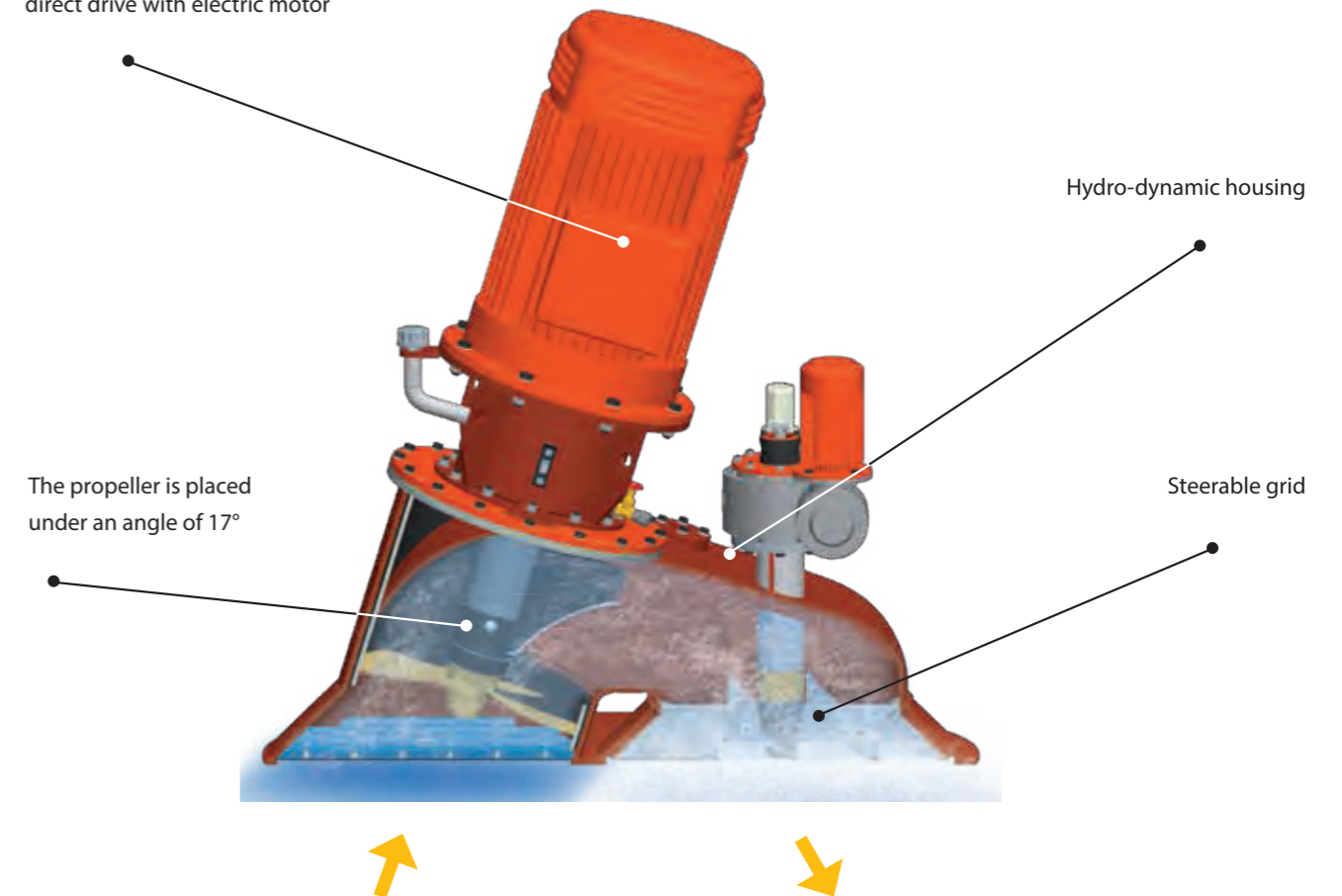



Doña Angela María T. | Type: VT-80

Veth Tunnel Thruster

Does your vessel have sufficient draft and you're looking for a traditional bow or stern thruster with maximum thrust to Port and Starboard? Then the Veth tunnel thruster is an interesting option.

As each vessel is unique, it may be that a regular tunnel thruster does not meet your needs. No problem, at Veth Propulsion you can also choose for aluminum, flexible mount (eventually combined with air injection), elbow or retractable thruster tunnel.



On our tunnel thrusters, we use a standard stainless steel pipe band in the tunnel at the height of the propeller. This makes our tunnel thrusters robust, durable and safe.

Is your accommodation located near the bow thruster? Then you would like to minimize noise and vibrations to increase comfort for your crew and passengers. The flexible mounted Veth Tunnel Thruster or a tunnel thruster with active noise suppression offer possibilities to keep the noise levels to a minimum.

Operation



Aluminum tunnel

For aluminum vessel we provide a tunnel thruster which consists of a steel gear unit in an aluminum tunnel. Here, the steel gear unit is mounted isolated from the aluminum construction.

Flexible mounted tunnel

The flexible mounted tunnel thruster is based on the standard tunnel thruster and improved to reduce noise and vibration levels created by the propeller and surrounding structure. This will increase comfort for crew (and passengers). The flexible tunnel provides noise reduction up to 10 dB.

Note: the final noise reduction is also dependent on other modifications in the vessel.

The complete unit (thruster + inner tunnel) is suspended in an outer tunnel, which damps out vibrations, and makes it possible to access the tunnel without dry docking if the draft allows it.

Veth Elbow Thruster

Do you need a smaller tunnel thruster for capacities up to 55 kW? Then the Veth Elbow Thruster offers the solution. The lack of a gearbox provides cost effectiveness and low maintenance.

Retractable tunnel thruster

Is a conventional tunnel thruster adequate in ports during mooring, but you desire a deep water, 360° steerable thruster with plenty of drive, for example, for your DP system or as an emergency propulsion? Then the retractable tunnel thruster can provide the solution for you.

The retractable thruster tunnel can also serve as (emergency) propulsion. This application is widely used in offshore vessels. In the upper position the tunnel functions as a PS-SB thruster, and in the lower position as a 360° steerable rudder propeller.

Advanced technology, robust, sustainable products are important in our offshore business. This combined with a good price/quality ratio and excellent service makes Veth Propulsion a valuable partner for our bow thrusters and rudder propellers.

Kees Eeltink, Manager Technical Department Acta Marine

Active Noise Suppression

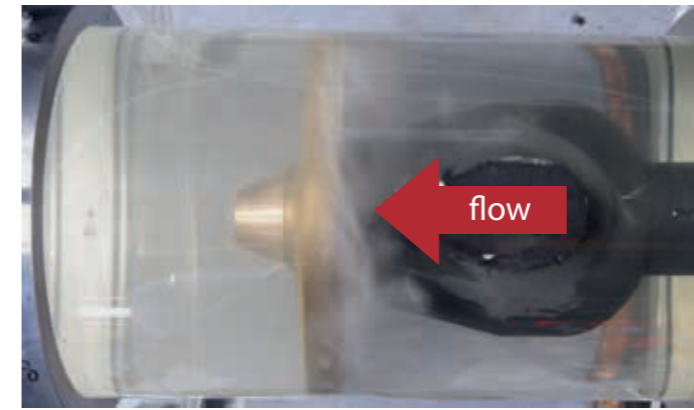

Thruster producing cavitation (imploding vacuum bubbles) - ANS off

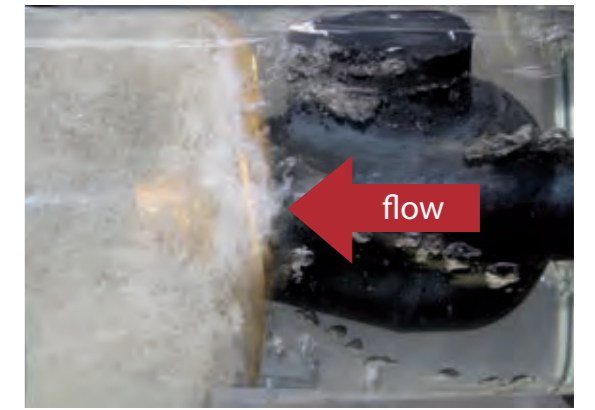

Compensating the vacuum bubbles with pressurized air bubbles - ANS on

Another solution to keep the tunnel thruster noise levels to a minimum is by employing an Active Noise Suppression (ANS) by means of compressed air injection. Compressed air is injected into the thruster's tunnel in front of the propeller's direction of flow, thus minimizing the effects of cavitation.

Active Noise Suppression using air injection is a cost effective way to decrease noise levels and cavitation damage in practically all new and existing tunnel thruster designs.

Operation and noise reduction up to 10 dB

By injecting air, the cavitation (vacuum) bubbles are compensated with pressurized bubbles, which carry them off before they are able to implode and cause noise and damage. The normal action of the propeller spreads the pressurized bubbles through the entire tunnel. The introduction of air has no effect on the thrust.

The actual reduction is dependent on the thruster model, speed of the propeller, vessel construction etc.

Active Noise Suppression is available for almost all sizes of Veth tunnel thrusters, both for new projects and for existing units already in operation.

[Please contact us for more information and possibilities](#)

Extensive testing has resulted in noise reductions up to 10 dB.

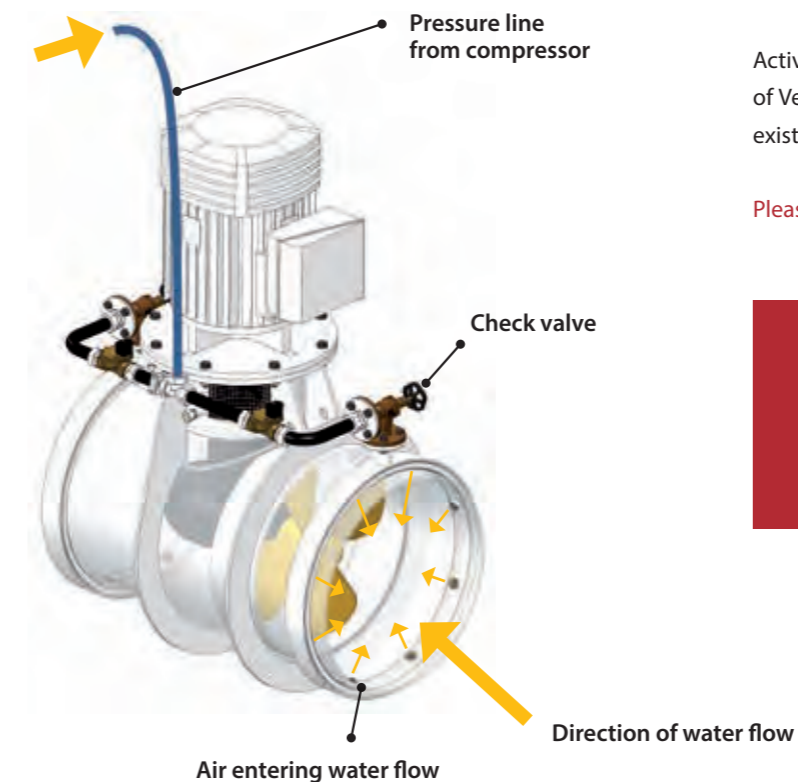

System activated - compressed air injected into tunnel's water flow



Damen 6711 | Type: VT-240



Don Amado | Type: VT-800



Acta Orion



Marietje Nora | Type: VT-300



Garp & Sark | Type: VT-80H

Operation

A streamlined right-angle gearbox with propeller is mounted in the tunnel. On top of the tunnel is a vertically mounted electric or hydraulic motor providing the drive in 2 directions (port and starboard).

The Veth range of tunnel thrusters are fitted to a wide range of vessels worldwide.

Type	Max. electrical power kW (Hp)	Input Speed (rpm)	Reduction	Propeller-diameter in mm
VT-50	64 (87)	1800	1,462:1	450
VT-80	120 (163)	1800	1,813:1	600
VT-100	130 (177)	1800	2,286:1	700
VT-180	168 (228)/202 (248)	1500/1800	2,286:1	850/800
VT-240	267 (363)	1500	2,571:1	980
VT-400	510 (694)	1500	2,923:1	1200
VT-550	545 (741)	1500	3,556:1	1350
VT-700	750 (1020)/740 (1006)	1000/1500	2,461:1/3,545:1	1500/1500
VT-900	966 (1313)/1000 (1360)	750/1500	2,375:1/4,273:1	1800/1600
VT-1250	1503 (2044)	900	3,083:1	2100

- The indicated values are based on intermediate duty and are subject to application and classification
- Values are for indication only. Power ranges for your specific application are available on request
- No rights can be taken from this sheet and data is subject to change without notice



Martin Sæle | VT-300 + VLT-550 (retractable)



Esnaad | Type: VT-80



Veth Control Systems

Like all of our products, all operating systems are also developed and produced in-house. The Veth control systems (VCS) offer you the opportunity to read out, monitor and analyze data and alarms.

Own R&D department

Veth Propulsion has its own R&D department for electronics, which is engaged daily with in-house development, innovation and improvement of our control systems. This is in line with the everything-under-one-roof principle and offers several advantages:



Fast service

- Single contact point
- Sufficient stock
- In-house knowledge and skills
- Not dependent on others

Interfacing with third party systems is developed and maintained internally: think of DP, Pilot and VDR interfaces

- The Veth Autopilot interface provides the ability to control the thruster asynchronously
- The DP interface provides safety around the DP control



Driven by simplicity

Also for our electronics Veth Propulsion believes in simplicity. For ourselves and for you as end user! You can contact us if you want a system that is maintenance and service friendly and obviously easy to use.

Latest technology

At Veth Propulsion you choose for a standard modular design. The choices we make are based on progressive and proven technology from the automotive industry. Through years of experience with systems and their users, Veth Propulsion can advise which systems are best suited to your specific needs and situation.

Quality, performance and appearance of the systems are closely monitored and continuously developed using the latest techniques.

Characteristics

- User friendly
- Standard with 3 languages (Dutch, German and English), more languages possible
- Low power consumption by deactivation of the system (Starting the system takes less than two seconds)
- User specific requirements possible
- Touchscreen panel with color display
- Fully dimmable panels (0% - 100%)



ELECTRIC DRIVEN TUNNEL THRUSTER

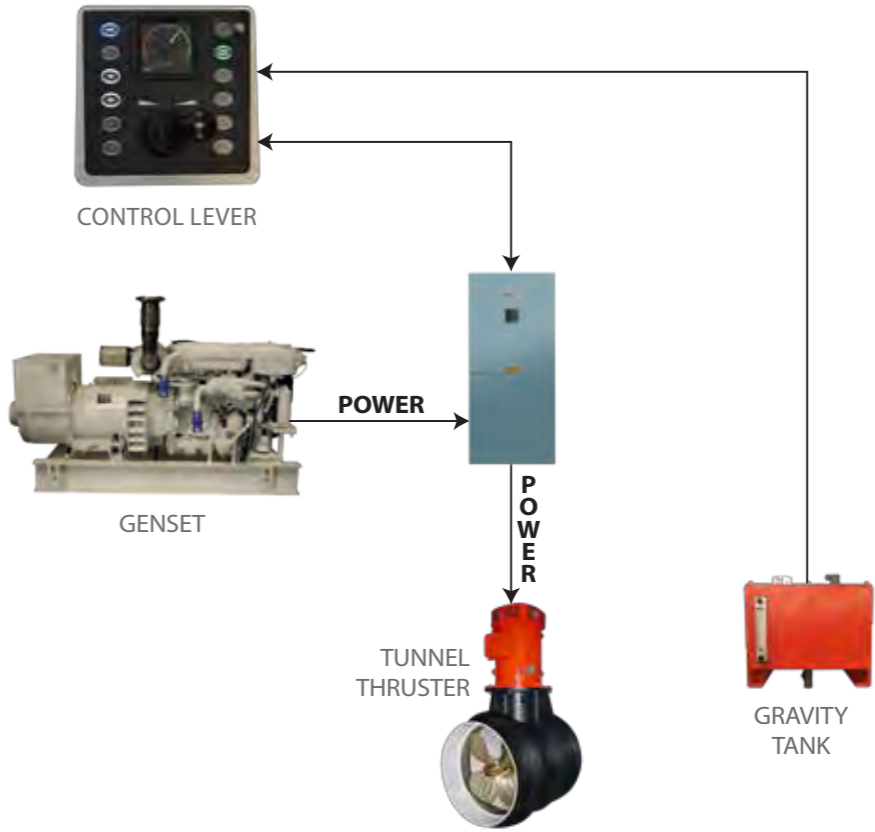

DIESEL DRIVEN VETH JET

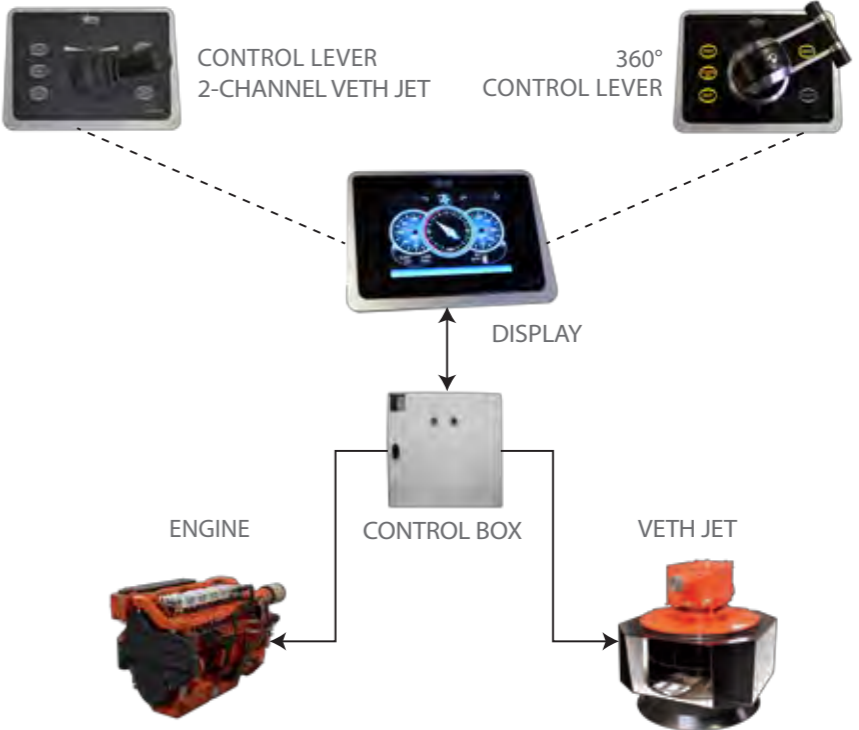

Global Dealer Network

- Veth Propulsion
- Twin Disc
- HQ / subsidiaries

For a current list of our dealer network worldwide, please check our websites.

Marine Applications



COMMERCIAL CRAFT

- Harbor Tug or ATB
- Push or Tow Boats/Inland Waterway (self-propelled barges)
- OSV (Oil, Gas)
- Salvage & Ice Breakers
- Fishing
- Dredging
- Seagoing vessels
- Passenger cruise vessels
- Offshore
- Ferries

(Self-propelled) Barges

PLEASURE CRAFT

- Yachts
- Super & Mega Yachts
- Racing
- Sport Fishing

FAST CRAFT

- Ferries & Taxis
- Pilot
- Survey Vessels
- Rescue & FiFI
- FSV (Fast Supply Vessel/Crew Boats)
- OWV (Offshore Windfarm Vessel)

MILITARY/COAST GUARD

- Patrol Craft
- Fast Attack

PLATFORM PROPULSION



VETH PROPULSION IS A PROUD MEMBER OF
THE TWIN DISC FAMILY OF PRODUCTS

THE TWIN DISC FAMILY OF PRODUCTS



Veth Propulsion • P.O. Box 53 • 3350 AB Papendrecht • T: +3178 615 22 66 • E: info@veth.net • www.vethpropulsion.com

UNITED STATES OF AMERICA • AUSTRALIA • BELGIUM • CANADA • CHINA • INDIA • ITALY • NETHERLANDS • SINGAPORE • SWITZERLAND

WWW.TWINDISC.COM • © 2019 TWIN DISC, INC